

This document is the property of Nian-Yeong Corporation and is delivered on the express condition that it is not to be disclosed, reproduced or used, in whole or in part, for manufacture or sale by anyone other than Nian-Yeong Corporation without its prior consent, and that no right is granted to disclose or to use any information in this document.

CUSTOMER DRAWING

REV.	DESCRIPTION	APPROVED BY	DATE	ECN NO.
A	RELEASE	Yeh Chou	2017/08/16	
B				
C				

CIRCUIT 1

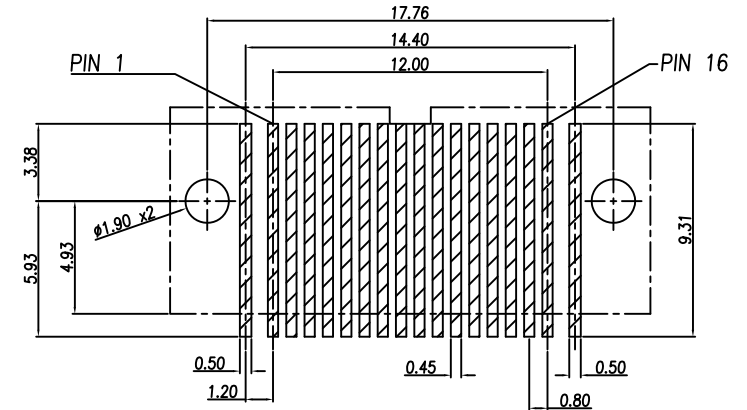
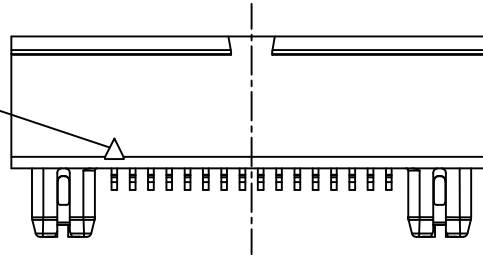

P.C.B LAYOUT

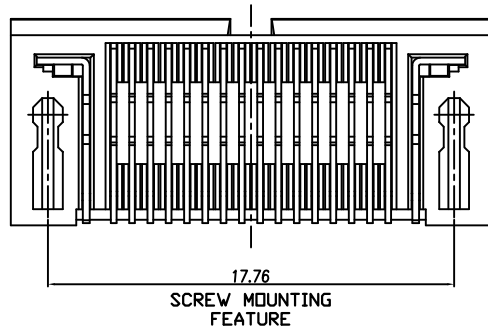

SCREW MOUNTING FEATURE

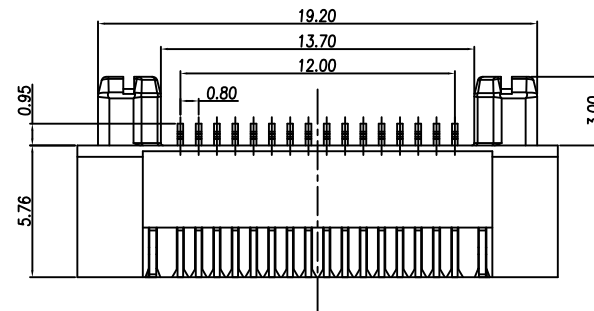
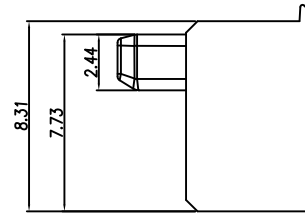
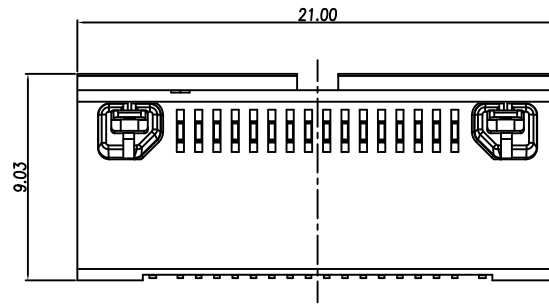

- MATERIAL :
 - 1-1. HOUSING : LCP UL94V-0 ; COLOR : BLACK
 - 1-2. CONTACT : PHOSPHOR BRONZE
 - 1-3. LATCHES : STAINLESS STEEL
- FINISH :
 - 2-1. CONTACT : CONTACT AREA : 5 MICRO INCHES MIN. GOLD PLATED SOLDER AREA : BRIGHT TIN UNDER PLATE : NICKEL
 - 2-2. LATCH SOLDER TAILS : BRIGHT TIN UNDER PLATE : MATTE TIN

DRAWN	Mark Kao	APP'D	Ku Chou	UNIT	mm	TOLERANCE		TITLE	HANDYLINK 16P (M) PERPENDICULAR TO PCB			SHEET
CHK'D	Emily Suen			SCALE	1:1	.x ±0.10 .xx ±0.05 .xxx ±0.03 .xxxx ±0.01 ANGULA ±1°		PART NO.	PC-16M2-08-11	DWG NO.	QC7904	VERSION
								NIAN YEONG ENTERPRISE			1	
								年永實業有限公司			2	
											A	

This document is the property of Nian-Yeong Corporation and is delivered on the express condition that it is not to be disclosed, reproduced or used, in whole or in part, for manufacture or sale by anyone other than Nian-Yeong Corporation without its prior consent, and that no right is granted to disclose or to use any information in this document.

CUSTOMER DRAWING

REV.	DESCRIPTION	APPROVED BY	DATE	ECN NO.
A	RELEASE	Yeh Chou	2017/08/16	
B				
C				

步驟一:

1. 將成品一一放入包裝盤內,依同一方向置入。
2. 包裝方式,如圖所示。
3. 一個包裝盤內放400pcs.

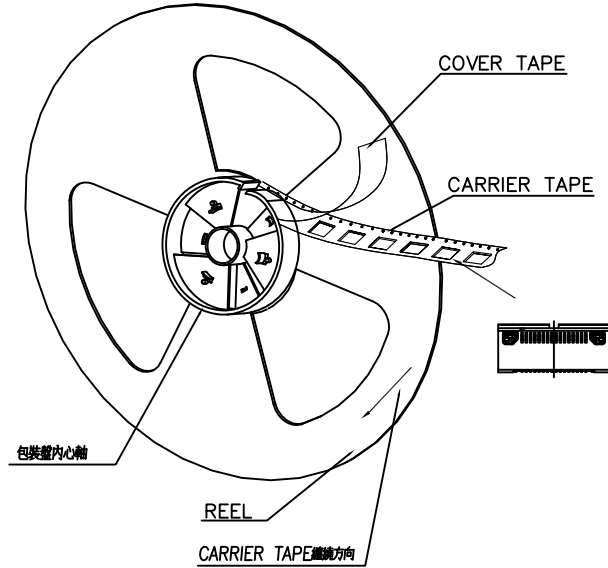

步驟二:

1. 一個紙箱可以裝10個包裝盤。
2. 每盤400pcs,每箱4Kpcs.
3. 將包裝盤放入防水袋中,包裝完後再封箱。

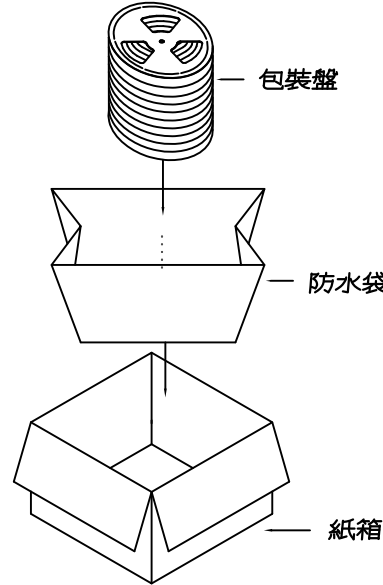

步驟三:

1. 用膠帶將紙箱封實。
2. 將標籤貼於紙箱上。

ITEM NO:
QTY: PGS
N. W. : KG
G. W. : KG
MEAS:

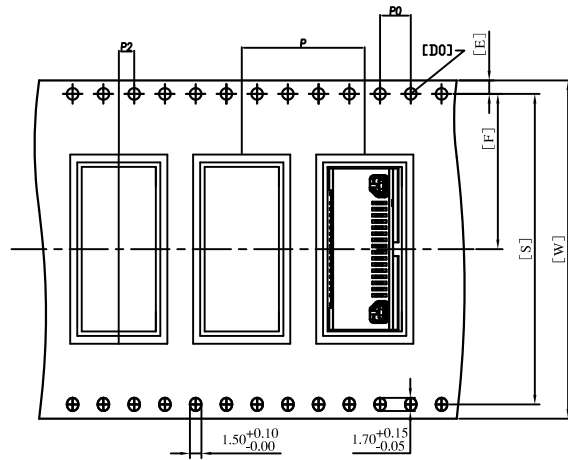
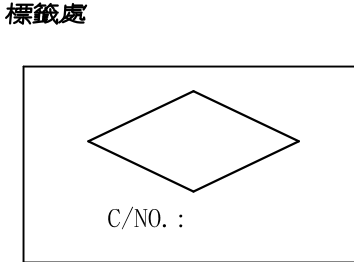

NOTE:

1. 若有未裝滿之零數箱,必須以緩衝材塞滿。
2. 在搬運過程中要輕拿輕放。
3. 載運輸中不可堆放過多,不可有重壓現象。
4. 在裝滿產品後,必須空留帶前和帶後15格以上,然後用紙膠布貼上。
5. 上帶在貼下帶時必須平整,且黏貼處不要出現氣泡。

W	56.00 ^{+0.30} _{-0.30}	T	0.50±0.05	P0	4.00±0.10	A0	8.70±0.10	A1
S	52.40±0.10	F	26.20±0.10	P2	2.00±0.10	B0	21.40±0.10	B1
E	1.75±0.10	P	16.00±0.10	D0	∅1.50 ± ^{0.10} ₀	K0	9.45±0.10	K1

DRAWN	Mark Kao	APP'D	Ku Chou	UNIT	mm	TOLERANCE	 NIAN YEONG ENTERPRISE 年永實業有限公司	TITLE	HANDYLINK 16P (M) PERPENDICULAR TO PCB			SHEET	2
CHK'D	Emily Suen			SCALE	1:1	.x ±0.20 .xx ±0.10 .xxx ±0.05 .xxxx ±0.03 ANGULA ±1°		PART NO.	PC-16M2-08-11	DWG NO.	QC7904	VERSION	B