

This document is the property of Nian-Yeong Corporation and is delivered on the express condition that it is not to be disclosed, reproduced or used, in whole or in part, for manufacture or sale by anyone other than Nian-Yeong Corporation without its prior consent, and that no right is granted to disclose or to use any information in this document.

# CUSTOMER DRAWING

REV.	DESCRIPTION	APPROVED BY	DATE	ECN NO.
A	RELEASE	Fido Weng	04/03/10*	
B	CHANGE CONTACT PLATED	Ku Chou	10/06/19	ECN-19006
C	CHANGE MATERIAL	Ku Chou	16/09/22*	

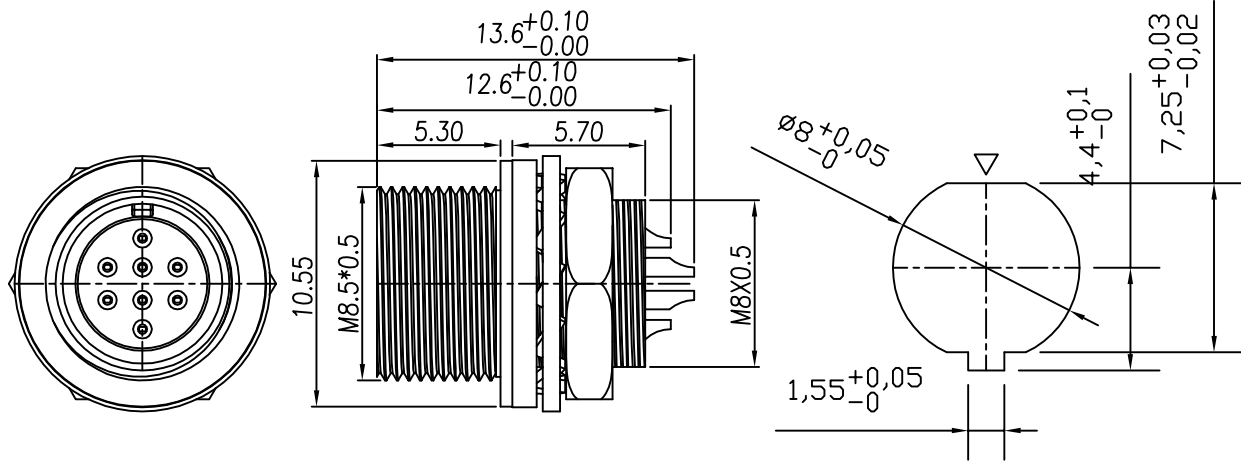

RECOMMEND PANEL CUT-OUT

- MATERIAL :
  - 1-1. HOUSING : NYLON 66 ; COLOR : BLACK
  - 1-2. CONTACT : PHOSPHOR BRONZE
  - 1-3. SHELL : Zinc Alloy
  - 1-4. NUT : BRASS
  - 1-5. O-RING : EPDM; COLOR : BLACK
  - 1-6. WASHER : BRASS
- FINISH :
  - 2-1. CONTACT : GOLD 10u"  $\Delta$
  - UNDER PLATE : NICKEL
  - 2-2. SHELL : NICKEL PLATED .
  - 2-3. NUT : NICKEL PLATED.
- ELECTRICAL SPECIFICATION :
  - 3-1. Rated current : 1A
  - 3-2. Rated voltage : 30V AC , 42V DC
- Environmental :
  - 4-1. Operation Temperature : -25℃~85℃

TABLE A

DI-04F2-02(4P)	DI-06F2-03(6P)	DI-08F2-02(8P)

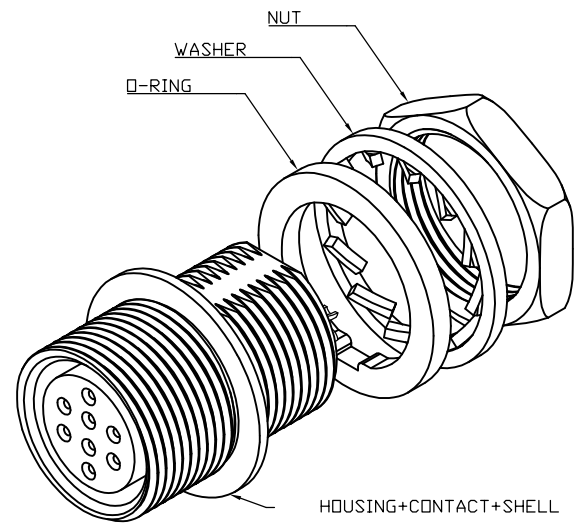

DRAWN	Jen Xie	APPEND	Emily Suen	UNIT	mm	TOLERANCE		TITLE	防水頭 M8*0.5 (F) 銅板			SHEET	1/2
CHOKED	Emily Suen			SCALE	1:1	.x ±0.20 .xx ±0.10 .xxx ±0.05 .xxxx ±0.03 ANGULA ±1°		PART NO.	SEE TABLE A	DWG NO.	QC5174	VERSION	C

NIAN YEONG ENTERPRISE  
年永實業有限公司

This document is the property of Nian-Yeong Corporation and is delivered on the express condition that it is not to be disclosed, reproduced or used, in whole or in part, for manufacture or sale by anyone other than Nian-Yeong Corporation without its prior consent, and that no right is granted to disclose or to use any information in this document.

# CUSTOMER DRAWING

REV.	DESCRIPTION	APPROVED BY	DATE	ECN NO.
A	RELEASE	Fido Weng	04/03/10*	
B	CHANGE CONTACT PLATED	Ku Chou	10/06/19	ECN-19006
C				

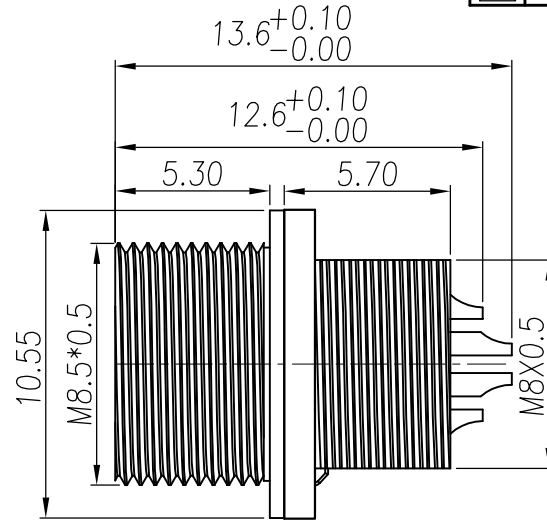
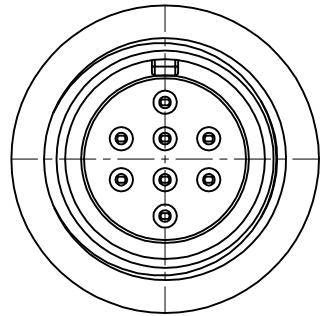

HOUSING+CONTACT+SHELL+O-RING

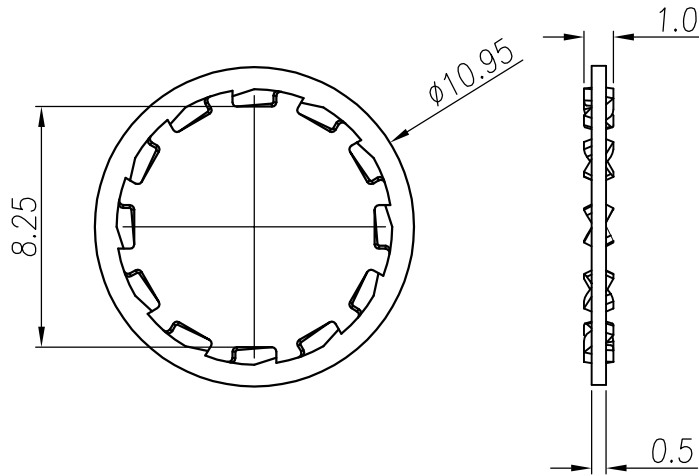

WASHER

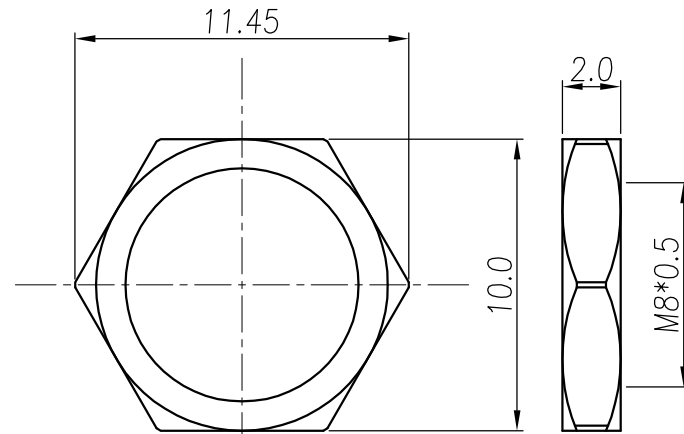

NUT

DRAWN	Jen Xie	APPEND	Emily Suen	UNIT	mm	TOLERANCE		TITLE	防水環 M8*0.5 (F) 銅板			SHEET	2/2
CHOKED	Emily Suen			SCALE	1:1	.x ±0.20 .xx ±0.10 .xxx ±0.05 .xxxx ±0.03 ANGULA ±1°			PART NO.	SEE TABLE A	DWG NO.	QC5174	VERSION

NIAN YEONG ENTERPRISE  
年永實業有限公司