

This document is the property of Nian-Yeong Corporation and is delivered on the express condition that it is not to be disclosed, reproduced or used, in whole or in part, for manufacture or sale by anyone other than Nian-Yeong Corporation without its prior consent, and that no right is granted to disclose or to use any information in this document.

CUSTOMER DRAWING

REV.	DESCRIPTION	APPROVED BY	DATE	ECN NO.
A	RELEASE	Ku Chou	20/07/18*	
B	CHANGE CLAMP RING MATERIAL	Ku Chou	31/10/18*	
C				

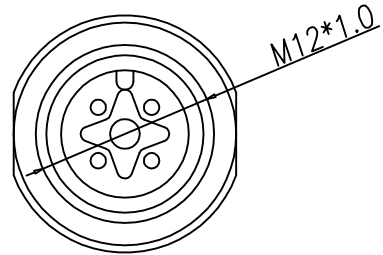
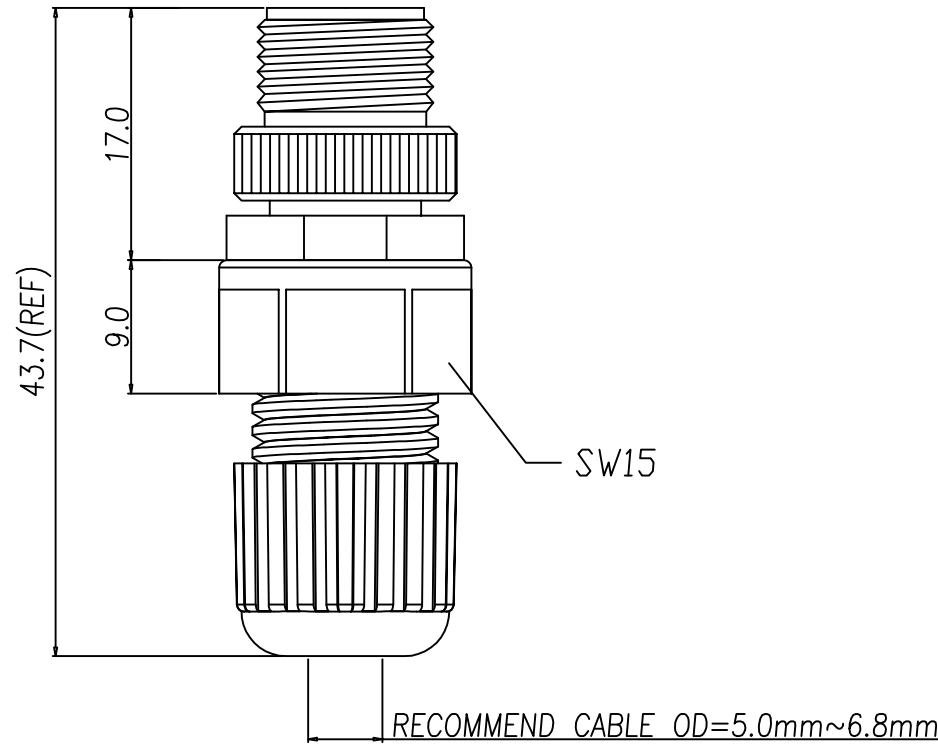

TABLE A

WP-05M2-130-11	WP-04M2-162-11	WP-03M2-112-11	WP-02M2-78-11
PIN ASSIGNMENTS FRONT VIEW			
		WP-03M2-144-11	WP-02M2-91-11



- MATERIAL :
 - 1-1. HOUSING : PBT UL94V-0 ; COLOR : BLACK.
 - 1-2. CONTACT : BRASS
 - 1-3. SHELL : BRASS
 - 1-4. NUT : ALUMINUM ALLOY
 - 1-5. GASKET : SILICONE
 - 1-6. CLAMP RING : PA66
 - 1-7. SEAL : SILICONE
 - 1-8. SEALING NUT : PA66
- FINISH :
 - 2-1. CONTACT : GOLD FLASH PLATED.
 - 2-2. NUT : NICKEL PLATED.
 - 2-3. SHELL : NICKEL PLATED.
- ELECTRICAL SPECIFICATION :
 - 3-1. Rated current : 4A
 - 3-2. Rated voltage : 4PIN 250V ; 5PIN 60V
 - 3-3. Water proof : IP67
- Environmental :
 - 4-1. Operation Temperature : -40°C~105°C

DRAWN	Emily Suen	APP'D	Ku Chou	UNIT	mm	TOLERANCE				TITLE	M12 (M) A-coded Assembly type(塑膠本體)			SHEET	1/2
CHK'D	Ku Chou	SCALE	1:1	.x	±0.20	.xx				±0.10	.xxx	±0.05	PART NO.	SEE TABLE A	DWG NO.
						.xxxx	±0.03	ANGULA	±1°						

This document is the property of Nian-Yeong Corporation and is delivered on the express condition that it is not to be disclosed, reproduced or used, in whole or in part, for manufacture or sale by anyone other than Nian-Yeong Corporation without its prior consent, and that no right is granted to disclose or to use any information in this document.

CUSTOMER DRAWING

REV.	DESCRIPTION	APPROVED BY	DATE	ECN NO.
A	RELEASE	Ku Chou	20/07/18'	
B	CHANGE CLAMP RING MATERIAL	Ku Chou	31/10/18'	
C				

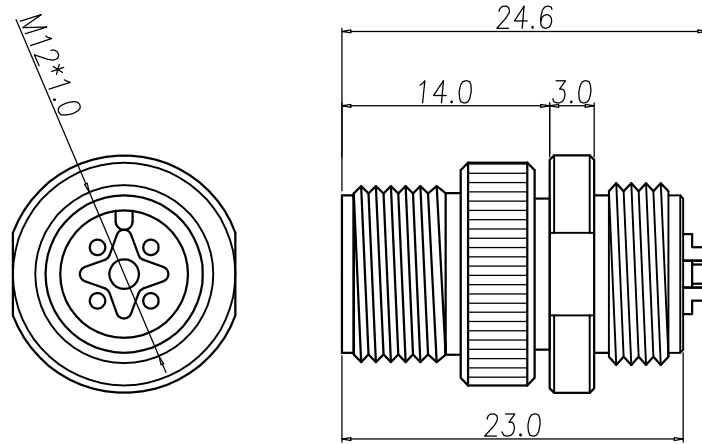

HOUSING & CONTACT & SHELL & NUT

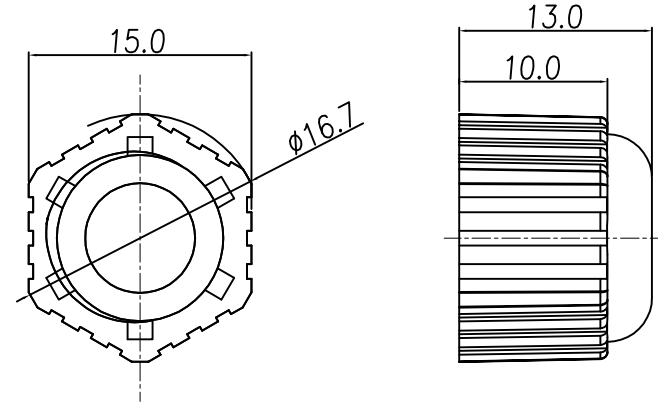

SEALING NUT

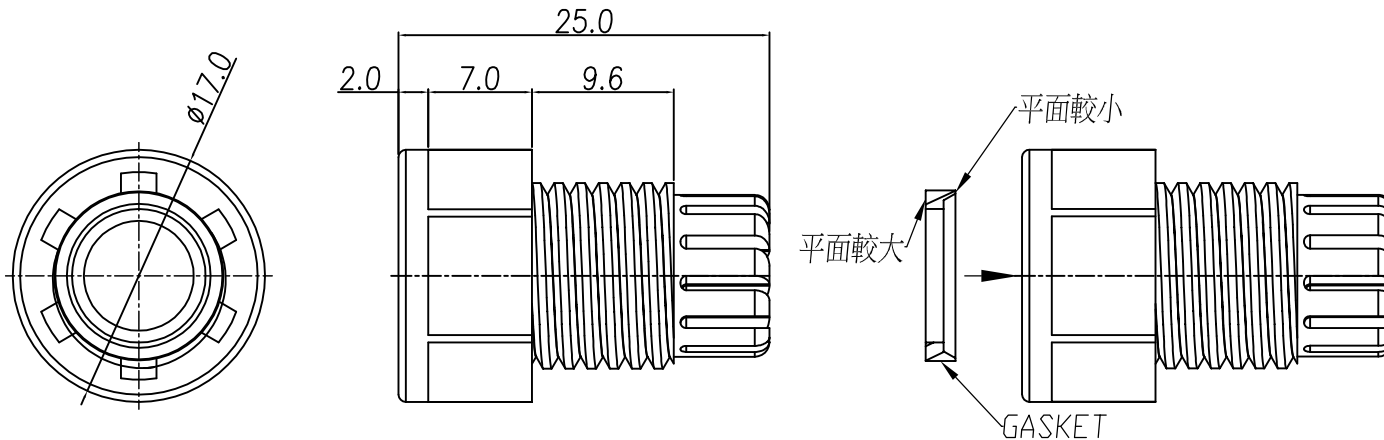

GASKET & CLAMP RING & SEAL

- MATERIAL :
 - 1-1. HOUSING : PBT UL94V-0 ; COLOR : BLACK.
 - 1-2. CONTACT : BRASS
 - 1-3. SHELL : BRASS
 - 1-4. NUT : ALUMINUM ALLOY
 - 1-5. GASKET : SILICONE
 - 1-6. CLAMP RING : PA66 \triangle
 - 1-7. SEAL : SILICONE
 - 1-8. SEALING NUT : PA66
- FINISH :
 - 2-1. CONTACT : GOLD FLASH PLATED.
 - 2-2. NUT : NICKEL PLATED.
 - 2-3. SHELL : NICKEL PLATED.
- ELECTRICAL SPECIFICATION :
 - 3-1. Rated current : 4A
 - 3-2. Rated voltage : 4PIN 250V ; 5PIN 60V
 - 3-3. Water proof : IP67
- Environmental :
 - 4-1. Operation Temperature : -40°C~105°C

DRAWN	Emily Suen	APP'D	Ku Chou	UNIT	mm	TOLERANCE			TITLE	M12 (M) A-coded Assembly type(塑膠本體)	SHEET	2
CHK'D	Ku Chou	SCALE	1:1			.x ±0.20 .xx ±0.10 .xxx ±0.05 .xxxx ±0.03 ANGULA ±1°			PART NO.	SEE TABLE A	DWG NO.	QC8673

NIAN YEONG ENTERPRISE
年永實業有限公司