

This document is the property of Nian-Yeong Corporation and is delivered on the express condition that it is not to be disclosed, reproduced or used, in whole or in part, for manufacture or sale by anyone other than Nian-Yeong Corporation without its prior consent, and that no right is granted to disclose or to use any information in this document.

CUSTOMER DRAWING

REV.	DESCRIPTION	APPROVED BY	DATE	ECN NO.
A	RELEASE	Ku Chou	20/11/18*	
B				
C				

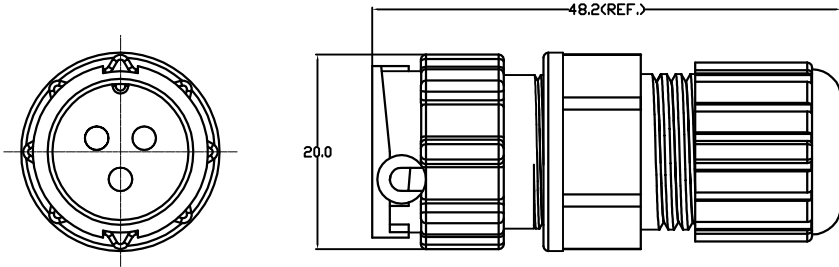
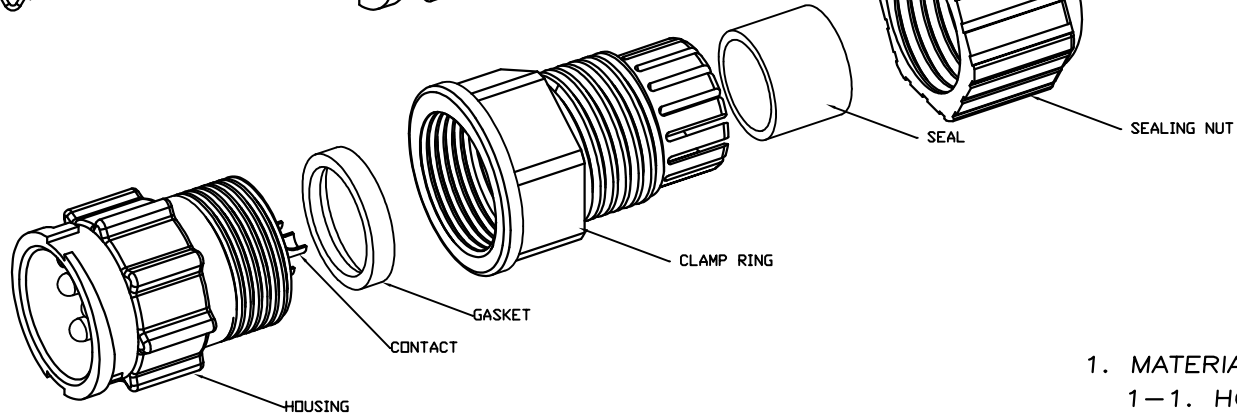
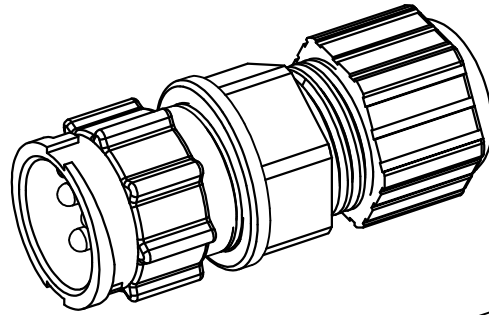
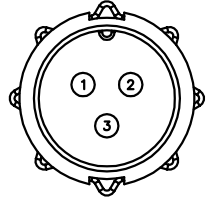

1. MATERIAL :
 - 1-1. HOUSING : PA66
 - 1-2. CONTACT : BRASS
 - 1-3. GASKET : SILICONE
 - 1-4. CLAMP RING : PA66
 - 1-5. SEAL : SILICONE
 - 1-6. SEALING NUT : PA66
2. FINISH :
 - 2-1. CONTACT : GOLD FLASH PLATED.
3. ELECTRICAL SPECIFICATION :
 - 3-1. Rated current : 20A
 - 3-2. Rated Voltage : 250V
 - 3-3. Water proof : IP67
4. Environmental :
 - 4-1. Operation Temperature : -40°C~105°C

DRAWN	Emily Suen	APP'D	Ku Chou	UNIT	mm	TOLERANCE	 NIAN YEONG ENTERPRISE 年永實業有限公司	TITLE	WP M CONN. M PIIN C SIZE ASSEMBLY TYPE(LOCK)-20A			SHEET	 VERSION A
CHK'D	Ku Chou			SCALE	1:1	.x ±0.20 .xx ±0.10 .xxx ±0.05 .xxxx ±0.03 ANGULAR ±1°		PART NO.	WP-03M2-108-11	DWG NO.	QC9082		