

This document is the property of Nian-Yeong Corporation and is delivered on the express condition that it is not to be disclosed, reproduced or used, in whole or in part, for manufacture or sale by anyone other than Nian-Yeong Corporation without its prior consent, and that no right is granted to disclose or to use any information in this document.

CUSTOMER DRAWING

REV.	DESCRIPTION	APPROVED BY	DATE	ECN NO.
A	RELEASE	YEH	15/10/15'	
B				
C				
D				

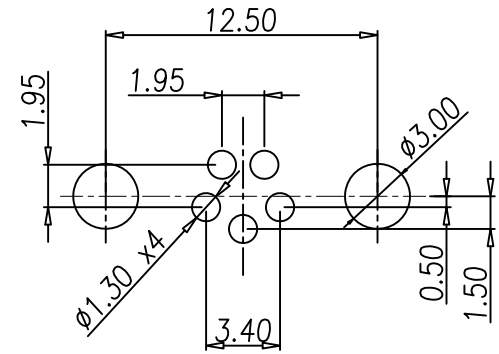
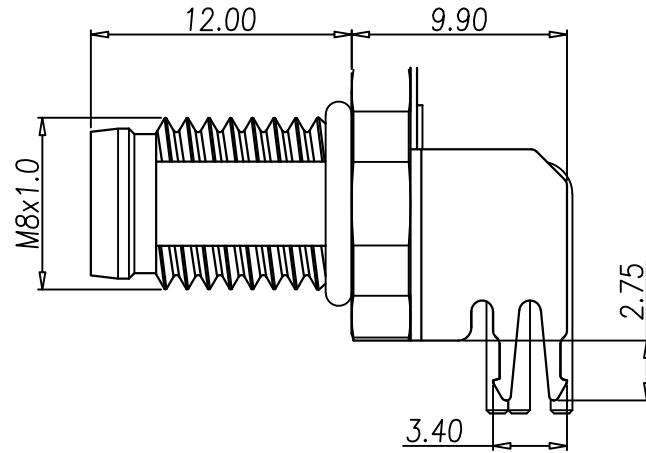
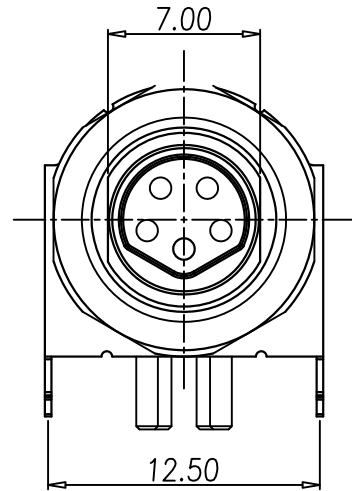

P.C.B LAYOUT

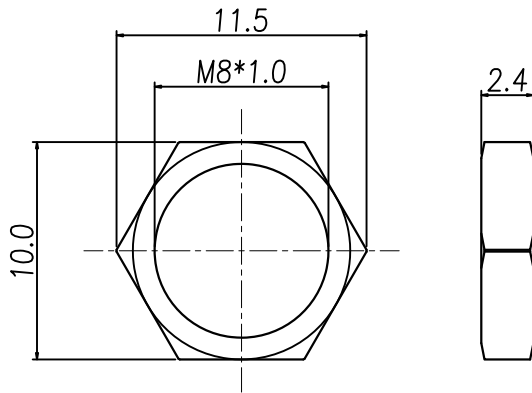
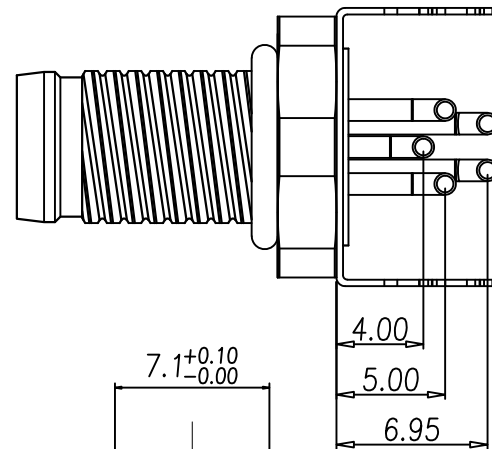

NUT

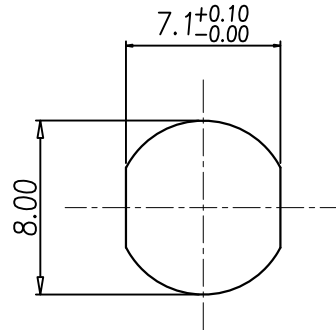

RECOMMEND PANEL CUT-OUT

- MATERIAL :
 - 1-1. HOUSING : PA UL94V-0 ; COLOR : BLACK
 - 1-2. CONTACT : BRASS.
 - 1-3. NUT : BRASS.
 - 1-4. SHELL : BRASS.
 - 1-5. O-RING : NBR
 - 1-6. GROUND : PHOSPHOR BRONZE
- FINISH :
 - 2-1. CONTACT : 10 MICRO INCHES MIN. GOLD PLATED
UNDER PLATE : NICKEL
 - 2-2. NUT : NICKEL PLATED
 - 2-3. SHELL : NICKEL PLATED
 - 2-4. GROUND : BIRGHT TIN PLATED
- ELECTRICAL SPECIFICATION :
 - 3-1. Rated current : 3A
 - 3-2. Rated Voltage : 30V
 - 3-3. Water proof: IP67
- Environmental :
 - 4-1. Operation Temperature : -40℃~85℃

DRAWN	Yeh Chou	APP'D	Ku Suen	UNIT	mm	TOLERANCE	NIAN YEONG ENTERPRISE		TITLE	Waterproof M8 5PIN (M) 前銷 90° DIP+接地			SHEET
CHK'D	Emily Suen			SCALE	1:1	.x ±0.20 .xx ±0.10 .xxx ±0.05 .xxxx ±0.03 ANGULA ±1°	年永實業有限公司		PART NO.	WP-05M3-01-11	DWG NO.	QC8030	VERSION A